

POWER UP





4TN101
3.8L
55-105kW

4TN107
4.6L
90-155kW

A close-up, high-angle view of a diesel engine's combustion chamber. The chamber is dark and metallic, with a bright orange and yellow flame burning in the center. The flame is contained within a circular opening at the top of the chamber. The surrounding engine components are dark and metallic, with some parts showing a brushed metal finish. The lighting is dramatic, highlighting the texture of the metal and the intensity of the flame.

***40 YEARS
OF EXPERIENCE IN
DIRECT INJECTION***

***LONG HISTORY OF IN-HOUSE PRODUCTION
OF FUEL INJECTION EQUIPMENT***

KEY FEATURES OF TNV-CR SERIES

**ORIGINAL
AIR MANAGEMENT
SYSTEM**

**NO AIR MASS FLOW
SENSOR CONCEPT**

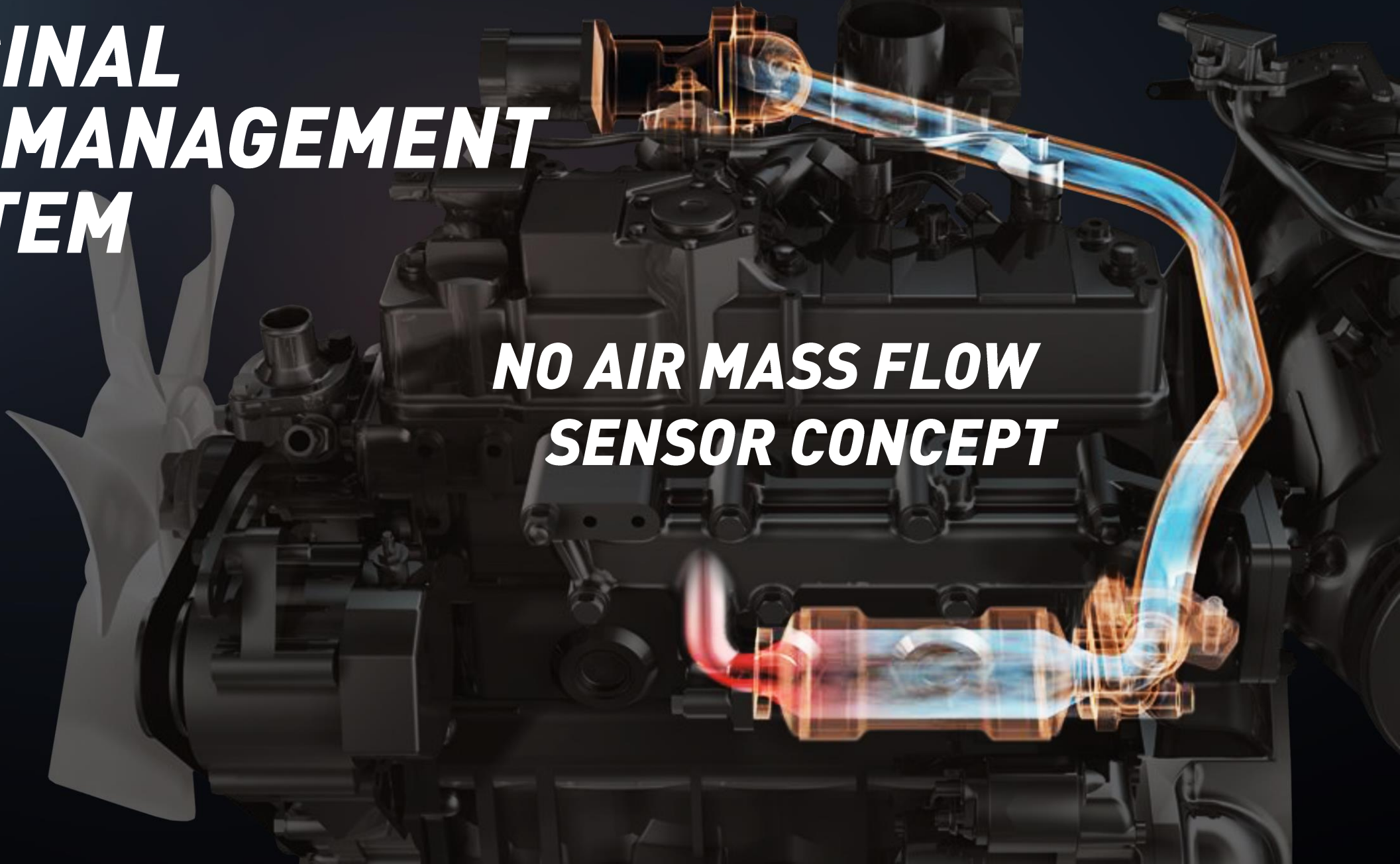

KEY FEATURES OF TNV-CR SERIES

ORIGINAL DPF REGENERATION CONTROL

2-STEP REGENERATION



DPF is the filter device designed to remove particulate matter (PM) from exhaust gas.

NEW KEY FEATURES

ORIGINAL COMBUSTION DESIGN

OPTIMIZED FOR EXTENDED POWER RANGE

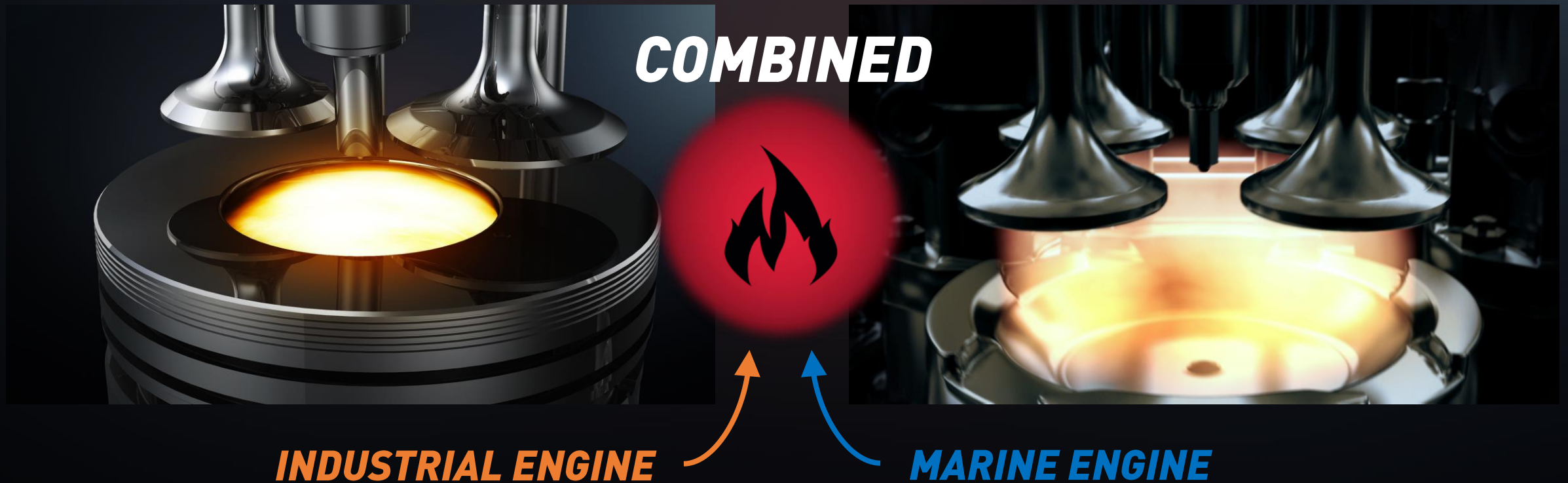

NEW KEY FEATURES

HIGHLY BOOSTED 2-STAGE TURBO CHARGER

155kW / 2,200min⁻¹

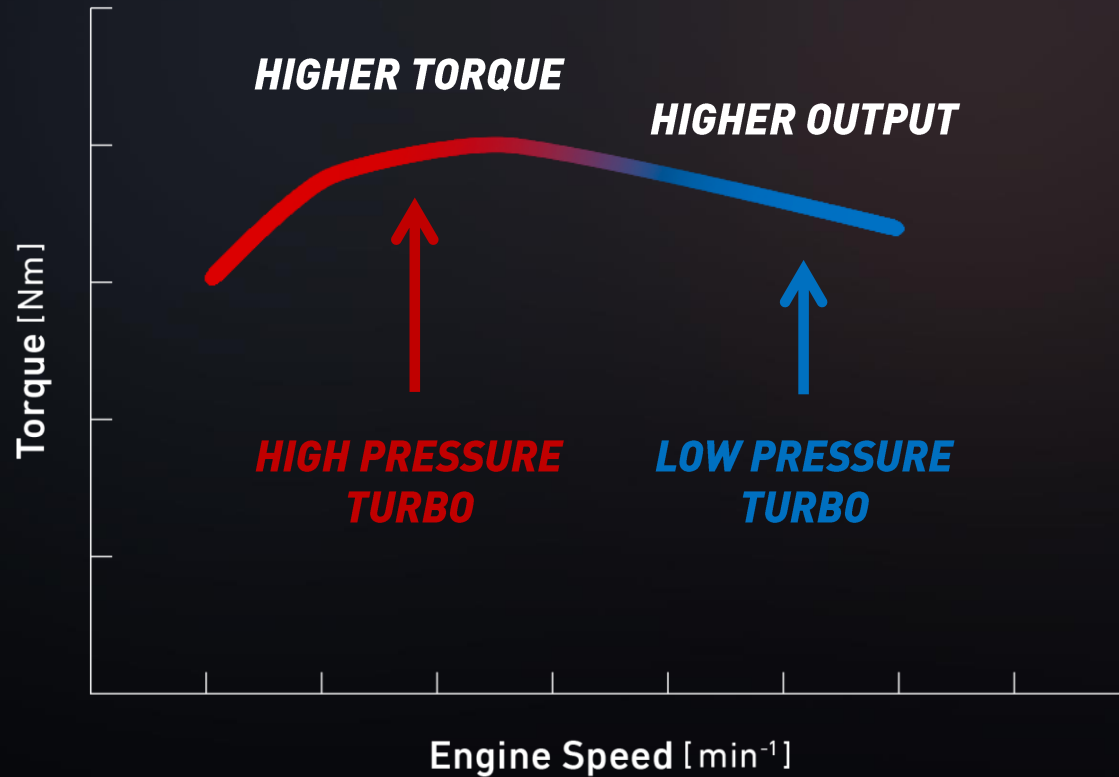

LOW PRESSURE



HIGH PRESSURE

NEW KEY FEATURES

DESIGN MILESTONES

**BEST MATCHING FOR
THIS POWER RANGE**

HIGHLY EFFICIENT COOLING CIRCUIT

INTEGRATED EGR SYSTEM

2000 BAR COMMON RAIL SYSTEM

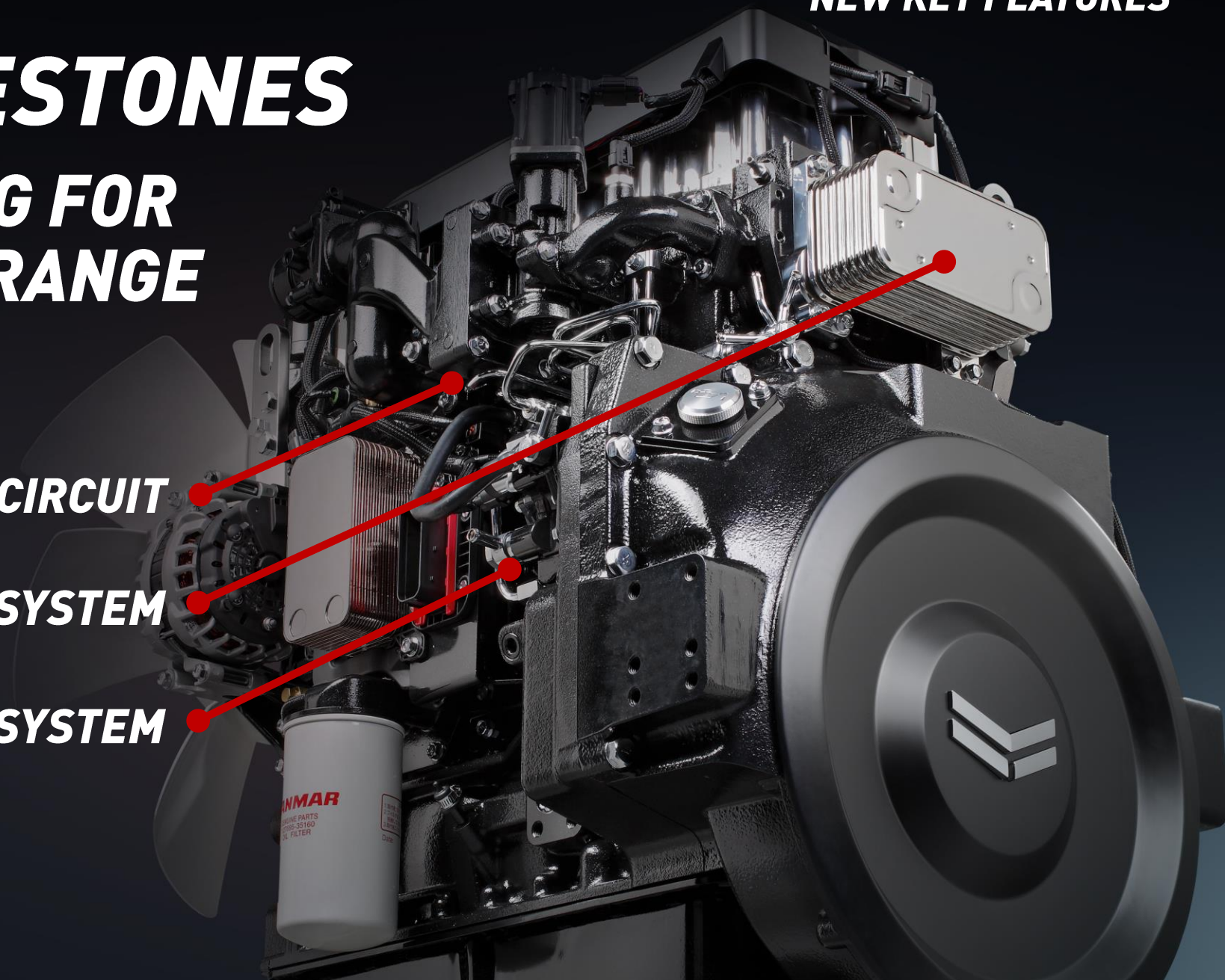

YANMAR'S ADVANTAGES

BEST IN CLASS
10% LESS FUEL
CONSUMPTION

Based upon the comparison of average industry standards with our test results.

YANMAR'S ADVANTAGES

HIGH POWER DENSITY

34kW/L

YANMAR'S ADVANTAGES

OUTSTANDING TORQUE
805Nm

COMPACT SIZE *4TN107*

YANMAR'S ADVANTAGES

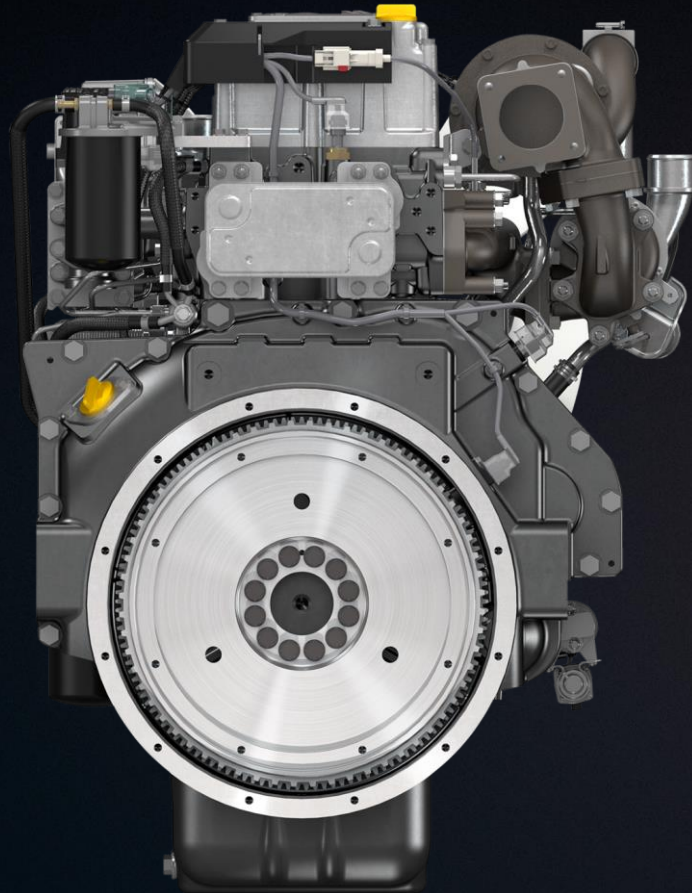

940 mm

730mm

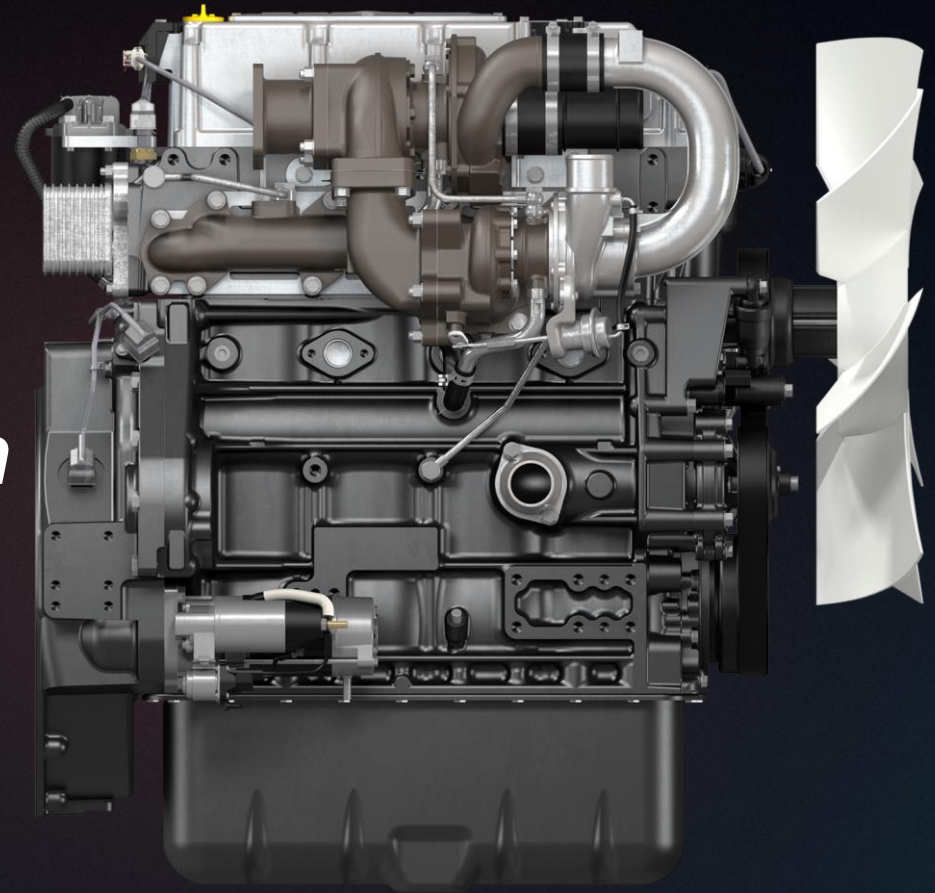

940mm



YANMAR'S ADVANTAGES

MAXIMIZE UPTIME
SEAMLESS OPERATION

WIDE POWER RANGE

4TN101

105kW

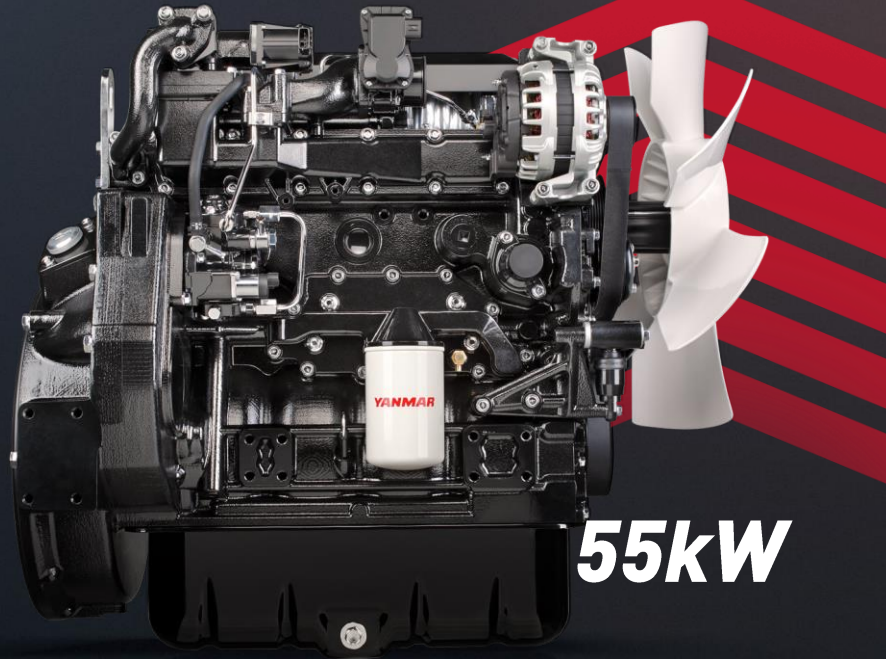

55kW

155kW

4TN107

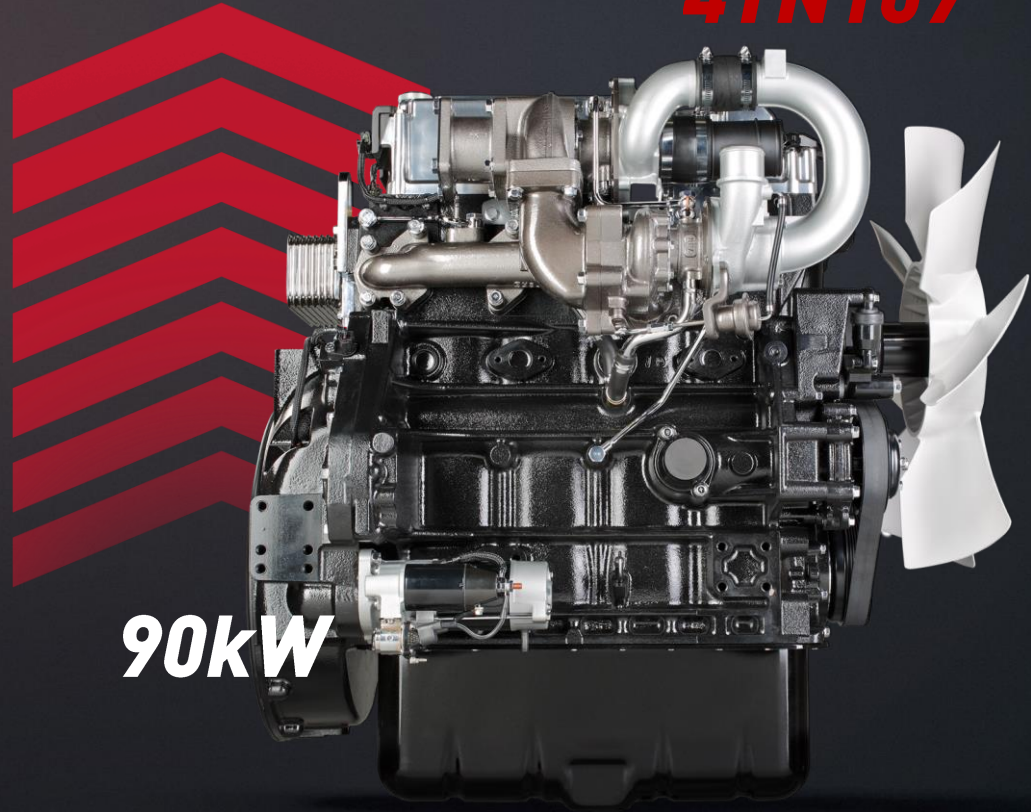

90kW

BEST CHOICE FOR OFF-ROAD

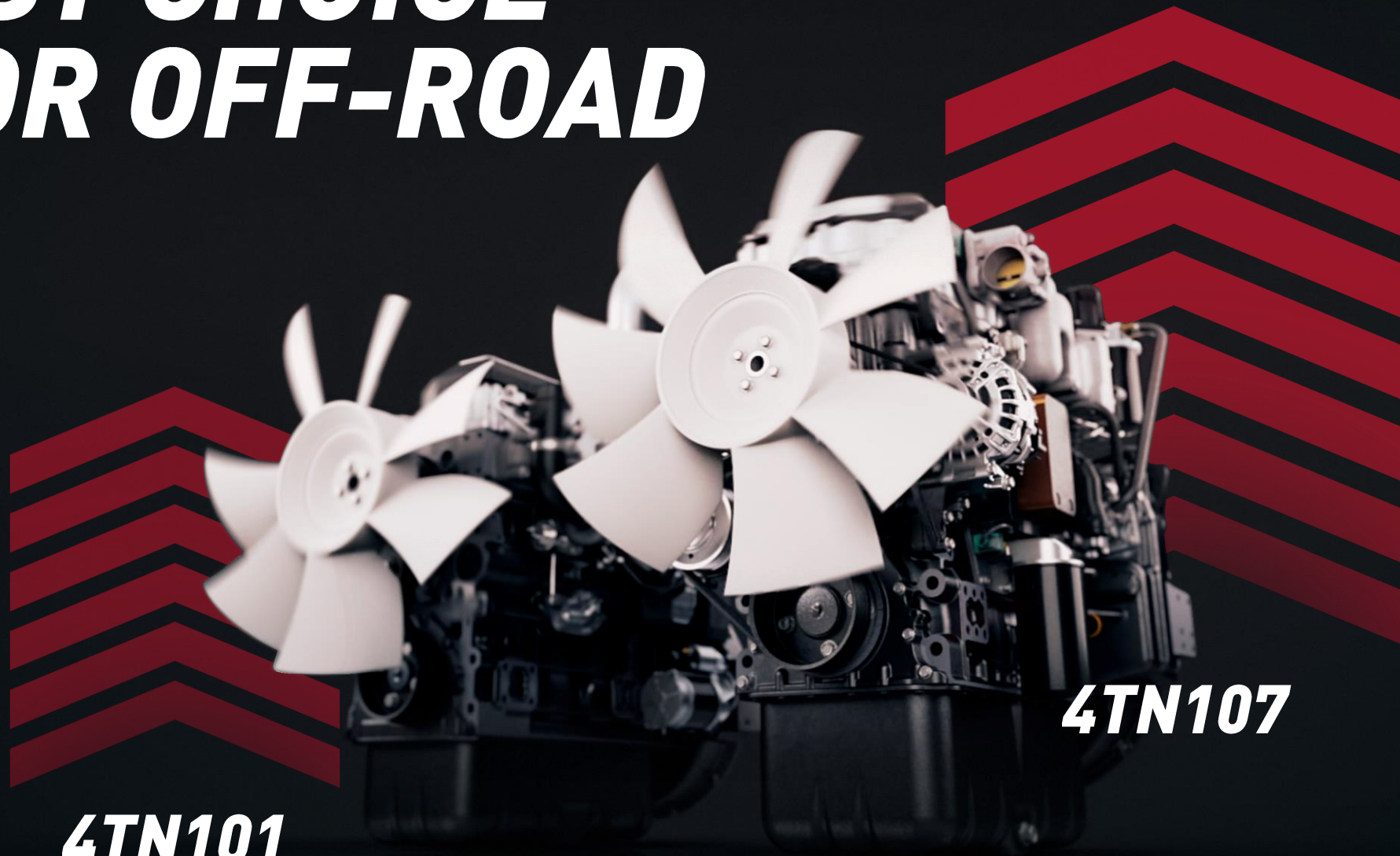

4TN101

4TN107

YANMAR

155kW



POWER UP NOW